



Removal of fine particles in wet flue gas desulfurization system by heterogeneous condensation

Linjun Yang*, Jingjing Bao, Jinpei Yan, Jinhui Liu, Shijuan Song, Fengxian Fan

School of Energy and Environment, Southeast University, Nanjing 210096, PR China

ARTICLE INFO

Article history:

Received 29 December 2008

Received in revised form

18 September 2009

Accepted 18 September 2009

Keywords:

Wet flue gas desulfurization
Heterogeneous condensation
Fine particles
Removal

ABSTRACT

A novel process to remove fine particles with high efficiency by heterogeneous condensation in a wet flue gas desulfurization (WFGD) system is presented. A supersaturated vapor phase, necessary for condensational growth of fine particles, was achieved in the SO₂ absorption zone and at the top of the wet FGD scrubber by adding steam in the gas inlet and above the scrubbing liquid inlet of the scrubber, respectively. The condensational grown droplets were then removed by the scrubbing liquid and a high-efficiency demister. The results show that the effectiveness of the WFGD system for removal of fine particles is related to the SO₂ absorbent employed. When using CaCO₃ and NH₃·H₂O to remove SO₂ from flue gas, the fine particle removal efficiencies are lower than those for Na₂CO₃ and water, and the morphology and elemental composition of fine particles are changed. This effect can be attributed to the formation of aerosol particles in the limestone and ammonia-based FGD processes. The performance of the WFGD system for removal of fine particles can be significantly improved for both steam addition cases, for which the removal efficiency increases with increasing amount of added steam. A high liquid to gas ratio is beneficial for efficient removal of fine particles by heterogeneous condensation of water vapor.

© 2009 Elsevier B.V. All rights reserved.

1. Introduction

Fine particles (PM_{2.5}) emitted from coal combustion are of environmental concern because they often consist of toxic components and can easily enter the human respiratory tract [1]. Although conventional dust removal devices such as electrostatic precipitators, cyclones and wet scrubbers have achieved high efficiencies, they face a strong challenge in reduction of PM_{2.5} emission. In practice, large amounts of fine particles are emitted into the ambient air, but increasing clean air demands require efficient removal of fine particles from coal-fired flue gas. Control of fine particles by improving the removal effect of present flue gas cleaning systems, and developing multi-pollutant control processes would be a significant technological achievement in this field.

At present, most large coal-fired power plants are equipped with WFGD systems downstream to an electrostatic precipitator. As the scrubbing effects of reagent solution, particulate matter can be removed simultaneously in a WFGD system. Wang et al. [2] have investigated the effectiveness of wet limestone-based FGD for removal of fine particles from a coal-fired power plant. The results showed that the grade removal efficiency declined, as expected,

with decreasing particle size, and fine particles in the outlet of the WFGD system comprised about 47.5% unreacted limestone and 7.9% gypsum product. Meij [3,4] found that after a wet limestone-based FGD system, all of the particulate matter emitted could be ascribed to PM_{2.5}, and consisted of about 40% coal-fired fly ash, 10% gypsum particles and 50% evaporated droplets saturated with gypsum. For a wet ammonia-based FGD, Yan et al. [5] reported that the number concentration of PM_{2.5} in the outlet of the scrubber was significantly higher than that in the inlet. Consequently, for coal-fired power plants equipped with WFGD systems, both the fly ash and aerosol particles formed during the SO₂ absorption process must be removed simultaneously. However, for the conditions prevailing in a wet FGD scrubber, the particle impaction and separation forces are weak for PM_{2.5}, so that a considerable portion of these particles may escape from the WFGD system, thus presenting an extremely difficult air pollution control problem.

The removal efficiency of fine particles can be considerably improved if they are enlarged by a pre-conditioning technique. One approach to pre-conditioning is the heterogeneous condensation of water vapor with fine particles acting as nucleation centers [6,7], for which a supersaturated water vapor environment is required. When the degree of supersaturation exceeds a critical value S_{cr} , the particles can be activated and grow into larger droplets that can be efficiently removed by inertial effects. Heterogeneous condensation of water vapor as a pre-conditioning technique for fine particle removal has been investigated for decades [8,9].

* Corresponding author. Tel.: +86 25 83795824.

E-mail address: yjl@seu.edu.cn (L. Yang).

Submicron particles can be efficiently separated from saturated warm gas streams in packed or sieve plate scrubbers trickled with cold water [10,11]. Heidenreich et al. [12,13] investigated the removal from saturated gas streams of submicron particles such as residual particles, quartz particles, and paraffin oil droplets, using a cascade of packed columns trickled with water which was alternately colder or warmer than the gas. Removal efficiencies higher than 90% were achieved in this manner. However, these processes cannot be directly applied to removal of fine particles from coal-fired flue gases, because either a large amount of steam must be added or the flue gas must be cooled significantly to achieve a saturated vapor phase at the inlet of the scrubber, due to the low moisture content and high temperature of flue gas streams [14]. In a previous study, we calculated the moisture content profiles of flue gas during scrubbing, and found that at the conditions prevailing in a wet FGD scrubber an unsaturated humid gas stream can also achieve supersaturation by simultaneous mass and energy transfer between the gas and liquid phases [15].

Heterogeneous condensation as a pre-conditioning technique is especially suitable for gas streams with high moisture content. In the wet FGD process, the hot flue gas contacts normal temperature scrubbing liquid. Simultaneous mass and energy transfer takes place, causing the gas phase temperature to decrease and the liquid phase to evaporate, entering the gas phase. Consequently, the relative humidity of flue gas can be greatly raised, allowing the flue gas after scrubbing approaches to be saturated with water vapor at a temperature of about 45–60 °C. Thus it is possible to produce a supersaturated vapor phase by improving the operating conditions of the WFGD system [15,16]. As soon as the degree of supersaturation exceeds S_{cr} , fine particles can be activated and subsequently grow to droplets with a size of some microns, which can easily be separated by means of a standard inertial separator, such as a wet scrubber or demister. To improve the removal of fine particles by heterogeneous condensation of water vapor in a WFGD system, the effectiveness of the WFGD system for removal of fine particles, and the influence of SO₂ absorbent species, liquid–gas ratio and the amount of steam added were investigated in the present study.

2. Experiments

2.1. Experimental set-up

The experimental set-up is shown schematically in Fig. 1. Flue gas with volume flux 70 N m³ h⁻¹ was generated by a coal-fired

boiler. Before entering a cyclone, the flue gas passed through a buffer vessel, where a stirrer and an electric heater ensured constant particle concentration and size distribution, and regulated the temperature of the flue gas. In the cyclone, large particles with aerodynamic diameter larger than 10 μm were separated from the flue gas. Steam was injected into the humidity conditioner to adjust the moisture content of the flue gas. Heat preservation was used for the buffer, the cyclone, the humidity conditioner and the pipelines. After passing through the humidity conditioner, the flue gas entered a spray scrubber where it passed countercurrent to the scrubbing liquid containing SO₂ absorbent. The scrubber, which was made of polycarbonate pipes and plates with excellent heat resistance, was divided into an SO₂ absorption zone and a condensational growth zone. The diameter and height of the scrubber were 150 mm and 2500 mm, respectively. Two high-efficiency wire mesh demisters were installed in the scrubber to remove the grown droplets.

In the experiments, three kinds of SO₂ absorbent, namely Na₂CO₃, CaCO₃ and NH₃·H₂O, were used to simulate the double-alkali, limestone-based and ammonia-based processes, respectively. The removal effect of water scrubbing was also investigated for comparison. A supersaturated vapor phase was achieved in two ways. The first method was increasing the moisture content of flue gas by injecting steam into the humidity conditioner (i.e. in the gas inlet of the scrubber), in combination with gas–liquid mass and energy transfer, to make the gas stream supersaturated in the SO₂ absorption zone. The second method was adding steam to the cold, humid flue gas from which SO₂ had been removed, to achieve a supersaturated vapor atmosphere at the top of the scrubber.

2.2. Sampling and analytical methods

At the inlet and outlet of the scrubber samples of gas were withdrawn isokinetically to measure particle size distribution and concentration in real time, using an electrical low pressure impactor (ELPI, Dekati Ltd., Finland). The ELPI has 13 stages (12 channels), and the measurement size range was 0.023–9.314 μm aerodynamic diameter. Due to the high moisture content of the sample gas stream, a special sampling set-up was used [14]. The sample gas was routed through a sampling gun to a cyclone where particles with aerodynamic diameter larger than 9.314 μm were separated. The sample gas was then diluted with particle free, hot dry air (dilution ratio 8.18:1) prior to entering the ELPI measurement system. In this way condensation of water vapor on the wall

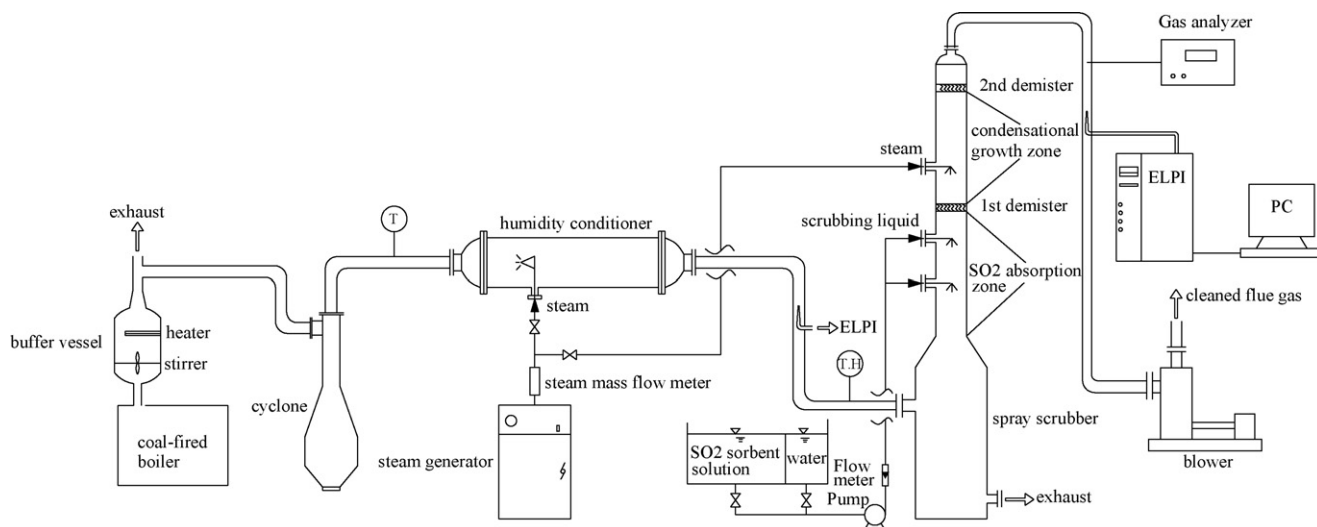

Fig. 1. Schematic diagram of experimental set-up.

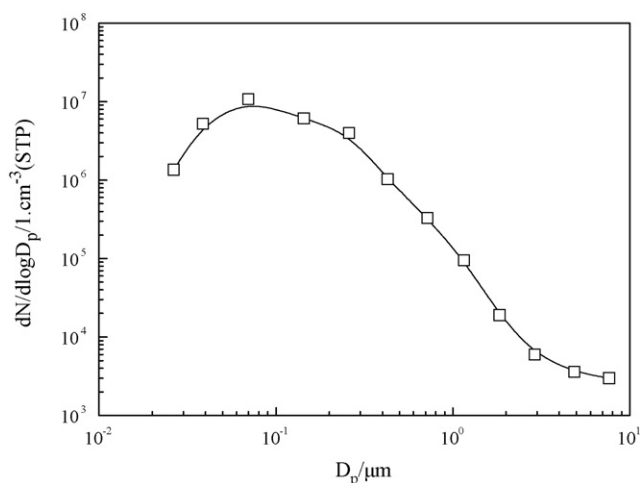

Fig. 2. Size distribution of coal-fired fine particles.

of sampling pipelines and on the impact plate of the ELPI was avoided.

The particle samples for morphology and elemental analysis were also taken isokinetically from the inlet and outlet of the scrubber, and were observed using field emission scanning electron microscopy/energy dispersive spectrometry (FESEM-EDS, Model FEI SIRION 200). SO_2 concentration was measured using a Delta 2000CD-IV flue gas analyzer (MRU GmbH, Germany).

2.3. Coal-fired fine particles

Coal-fired fine particles were generated by a coal-fired boiler burning anthracite. Fig. 2 shows the particle size distribution measured by the ELPI, and displays a unimodal distribution in the number concentration, which may be attributed to the combustion condition, coal and boiler type employed. Yi et al. [17] found that the fine particles number size distribution shows a great difference among the power plants in China, and bimodal distribution characteristics is not evident for some power plants. In addition, the unimodal distribution characteristics is also related to the definition of concentration (number concentration or mass concentration). In our experiments, the mass size displayed a bimodal distribution occasionally. As can also be seen from Fig. 2, the fine particles were mostly in the submicron size range with maximum number concentration at $0.07 \mu\text{m}$, and the number concentrations were of the order $(2.0\text{--}3.0) \times 10^7 \text{ cm}^{-3}$.

3. Results and discussion

3.1. Influence of WFGD system on morphology and elemental composition of fine particles

Fig. 3 shows SEM/EDS analysis results of fine particles before and after scrubbing. Most particles in the raw flue gas appeared to be spherical, and the main elements were O, Al, Si and C, together with lesser proportions of Ca, S, Fe, K, Na etc. (the source of the Pt signal is the platinum coating that was applied to the particle samples for SEM analysis), as shown in Fig. 3(a). From these results, it can be concluded that the coal-fired fine particles are mainly insoluble aluminosilicates, which are not perfectly wettable substances and higher supersaturation is required to activate the particles [18]. Fig. 3(b) shows that after the wet limestone-based FGD particles with block structure appeared, and the elemental concentrations of Ca, S and O increased. This means that the fine particles at the outlet of the limestone scrubber probably contained sulfates and sulfites,

and unreacted limestone. The micrograph in Fig. 3(c) indicates that the particle morphology after ammonia-based FGD was markedly different from that before scrubbing. Most particles had regular crystal structures, with some fine particles adsorbed on their surfaces, and some cubic and prismatic crystals were formed, which are normal crystal habits for $(\text{NH}_4)_2\text{SO}_4$ and $(\text{NH}_4)_2\text{SO}_3$. Moreover, the elemental concentrations of S and O significantly increased, and N was detected. These changes arise because before scrubbing the fine particles are mostly submicron coal-fired fly ash particulates, formed primarily by vaporization–condensation as spherical structures [19]. During the ammonia-based process, however, crystalline particles such as $(\text{NH}_4)_2\text{SO}_3$, NH_4HSO_3 and $(\text{NH}_4)_2\text{SO}_4$ can be formed through chemical reaction between SO_2 in the flue gas and gaseous ammonia volatilized from ammonia solution [20,21]. In addition, the solid particles can also be generated by evaporation of salt solution droplets under the effect of the hot flue gas. When Na_2CO_3 was used to remove SO_2 from flue gas, the morphological characteristics of the fine particles were not distinctly different from that of water scrubbing, but the elemental concentrations of Na, S and O were somewhat increased.

3.2. Effectiveness of WFGD system for removal of fine particles

The fine particle number removal efficiencies for the WFGD system are given in Fig. 4. In these experiments, the liquid to gas ratio (L/G) was 15 L N m^{-3} , and the initial particle number concentration (C_N) was about $(2.0\text{--}3.0) \times 10^7 \text{ cm}^{-3}$. It can be seen that the effectiveness of the WFGD system for removal of the fine particles was related principally to the reagent employed, and the effect of liquid-to-gas ratio seems to be relatively weak except for $\text{NH}_3\text{--H}_2\text{O}$ as reagent. The removal efficiency for the wet limestone-based process was lower than that for water scrubbing. This can probably be attributed to the presence of sulfate and sulfite products, and to the unreacted limestone particulate matter in flue gas, leading to the increase of fine particle concentration. The double-alkali process, using Na_2CO_3 as SO_2 absorbent, has some ability to remove fine particles, which is only slightly lower than that of water scrubbing under the same conditions. This is due to the fact that the solubility of sodium salts is much higher than that of calcium salts, so that they form crystals with difficulty and the particle number concentration does not increase significantly. For the ammonia-based process, the negative removal efficiencies reflect the formation of fine particles across the scrubber. However, the extent of fine particle formation decreases with an increase in L/G. The reason for this trend is that the mole ratio of NH_3 to SO_2 was kept constant in the experiments, so that the concentration of ammonia in solution was reduced and NH_3 thus volatilized to a lesser extent with increasing L/G, and fewer aerosol particles were formed.

3.3. Improved removal of fine particles by heterogeneous condensation

In coal-fired power plants equipped with the WFGD system, the aerosol particles formed during the SO_2 absorption process must be removed in addition to the fly ash. From Fig. 4 it is apparent that the effectiveness of the WFGD system for removal of fine particles is limited. In general, conventional wet FGD systems are relatively inefficient in removing $\text{PM}_{2.5}$, whereas removal efficiencies of 70–80% can be achieved for particles with size larger than $3\text{--}5 \mu\text{m}$. It follows that efficient removal of fine particles can be attained if the fine particles are enlarged to a size of the order several microns by a pre-conditioning technology. For the WFGD system heterogeneous condensation of water vapor, with the fine particles acting as nucleation centers, is especially suitable for this purpose, and may be realized in two ways, as follows:

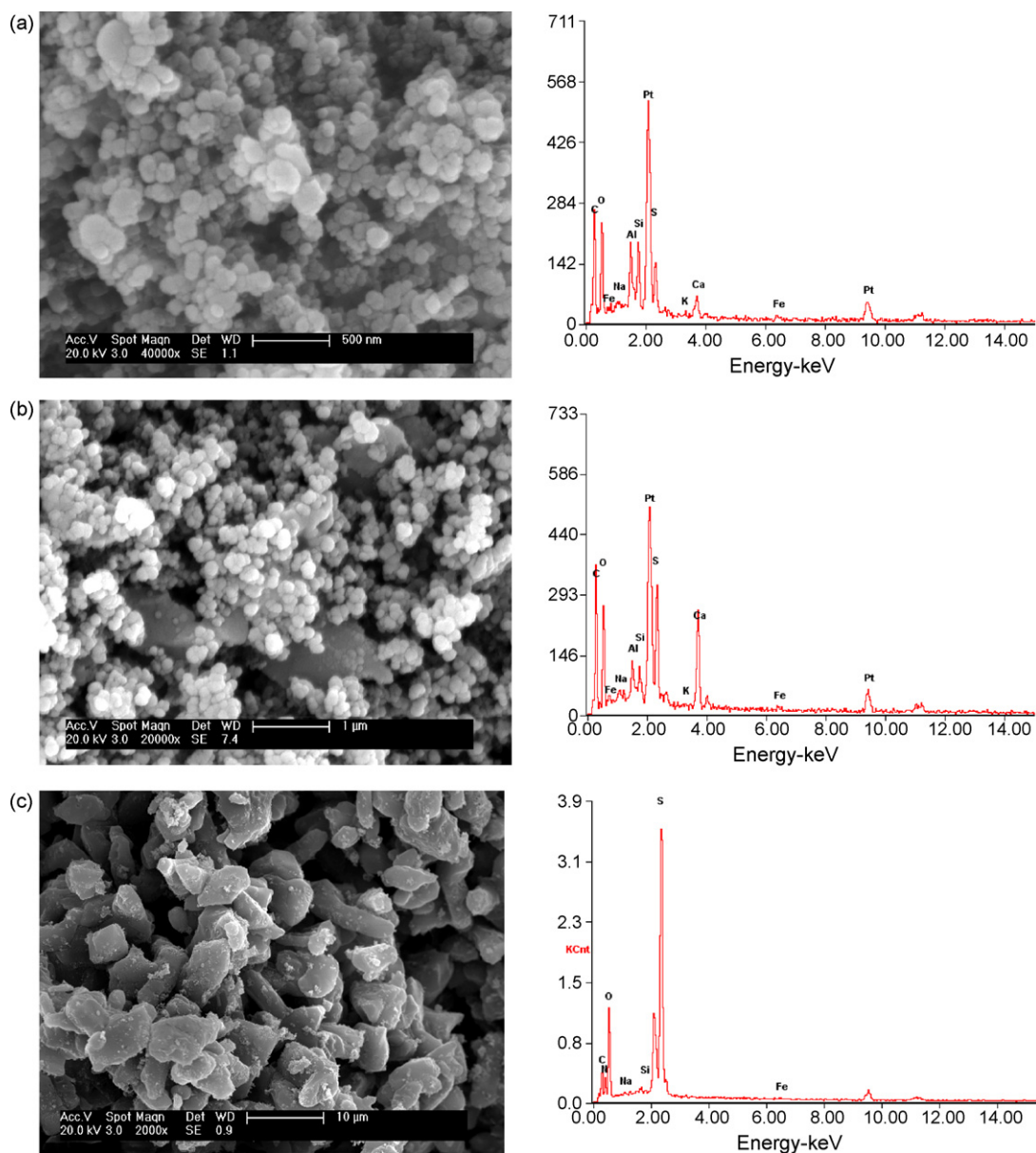

Fig. 3. SEM/EDS analysis results of fine particles from WFGD inlet and outlet flue gas. (a) WFGD inlet, (b) WFGD outlet with CaCO_3 slurry scrubbing and (c) WFGD outlet with $\text{NH}_3\text{-H}_2\text{O}$ solution scrubbing.

(1) Condensational growth and removal of fine particles in the SO_2 absorption zone.

To illustrate the degree of supersaturation achieved by combining steam addition to the inlet flue gas with gas–liquid mass and energy transfer, numerical calculations of saturation profiles in the SO_2 absorption zone were performed, assuming that the particle number concentration C_N is $2.0 \times 10^7 \text{ cm}^{-3}$, and neglecting the formation of aerosol particles during desulfurization. Fig. 5 gives the saturation profiles for different amounts of added steam, where the inlet gas temperature $T_{G,\text{in}}$ is 120°C , the inlet scrubbing liquid temperature $T_{L,\text{in}}$ is 40°C , and the liquid–gas ratio L/G is 15 L N m^{-3} . The result shows that the gas is unsaturated for conventional SO_2 absorption without steam addition. Supersaturation in the SO_2 absorption zone can be achieved by introducing sufficient steam into the inlet gas. With addition of $0.06 \text{ kg steam per N m}^3$ flue gas, the maximum supersaturation of about 1.35 can be achieved. As soon as the supersaturation of the vapor phase exceeds the corresponding critical value, the fine particles will be activated and

grow to larger droplets. The resulting droplets can be effectively removed by the scrubbing liquid and demister.

(2) Condensational growth and removal of fine particles in the top of the scrubber.

During wet FGD the relative humidity of flue gas can be greatly increased, allowing the gas, from which SO_2 has been removed, approach to be saturated with water vapor at about $45\text{--}60^\circ\text{C}$. Hence, a supersaturated vapor phase can be attained by adding a little steam to the high-humidity gas stream. Heidenreich and Ebert [6] have shown that with a mass of condensable water vapor of 5.5 g m^{-3} and particle number concentration $1.0 \times 10^5 \text{ cm}^{-3}$, the submicron particles can be enlarged to droplets with mean diameter $3 \mu\text{m}$ within 30–50 ms. Therefore, the space for condensational growth of fine particles could be a small zone as a result of the high growth rates, which offers the possibility of using the upper zone above the scrubbing liquid inlet of the scrubber as a condensational growth chamber.

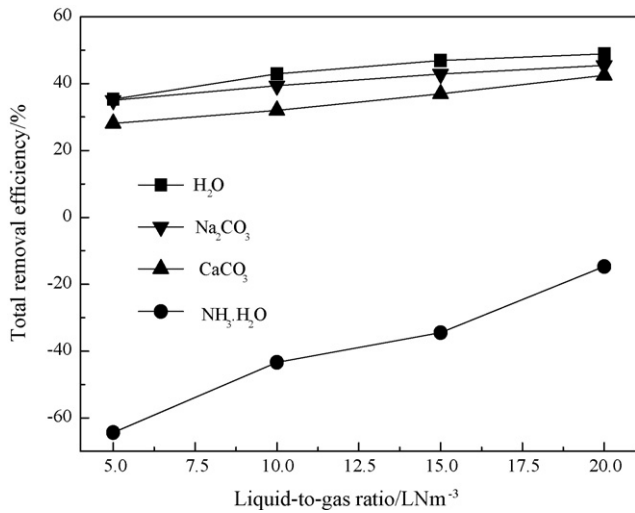

Fig. 4. Removal performance of WFGD system on fine particles at $L/G = 15 \text{ LN m}^{-3}$, $C_N \approx (2.0\text{--}3.0) \times 10^7 \text{ cm}^{-3}$.

3.3.1. Grade removal efficiency

Fig. 6 shows the grade number removal efficiency of fine particles by the WFGD system for three cases, which can be described as without steam addition, steam addition in the gas inlet, and steam addition above the scrubbing liquid inlet. For the cases with steam addition, the amount of steam added, m_s , was $0.06 \text{ kg steam per N m}^3$ dry flue gas, in both cases. It is obvious that the effectiveness of WFGD system for the removal of fine particles, especially sub-

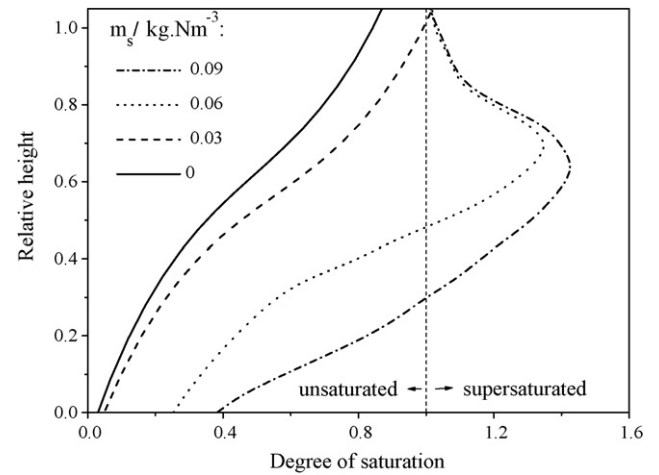

Fig. 5. Saturation profiles in SO_2 absorption zone at different amounts of added steam under the following conditions: $C_N = 2.0 \times 10^7 \text{ cm}^{-3}$, $T_{G,\text{in}} = 120^\circ \text{C}$, $T_{L,\text{in}} = 40^\circ \text{C}$, $L/G = 15 \text{ LN m}^{-3}$.

micron particles from 0.1 to $1.0 \mu\text{m}$ in diameter, was significantly improved for both steam addition cases. The reason is that supersaturated vapor phase, necessary for the condensational growth of fine particles, can be achieved either in the SO_2 absorption zone or at the top of the scrubber. Thus vapor can be condensed on the particle surface, and the enlarged particles can be effectively removed by inertial forces.

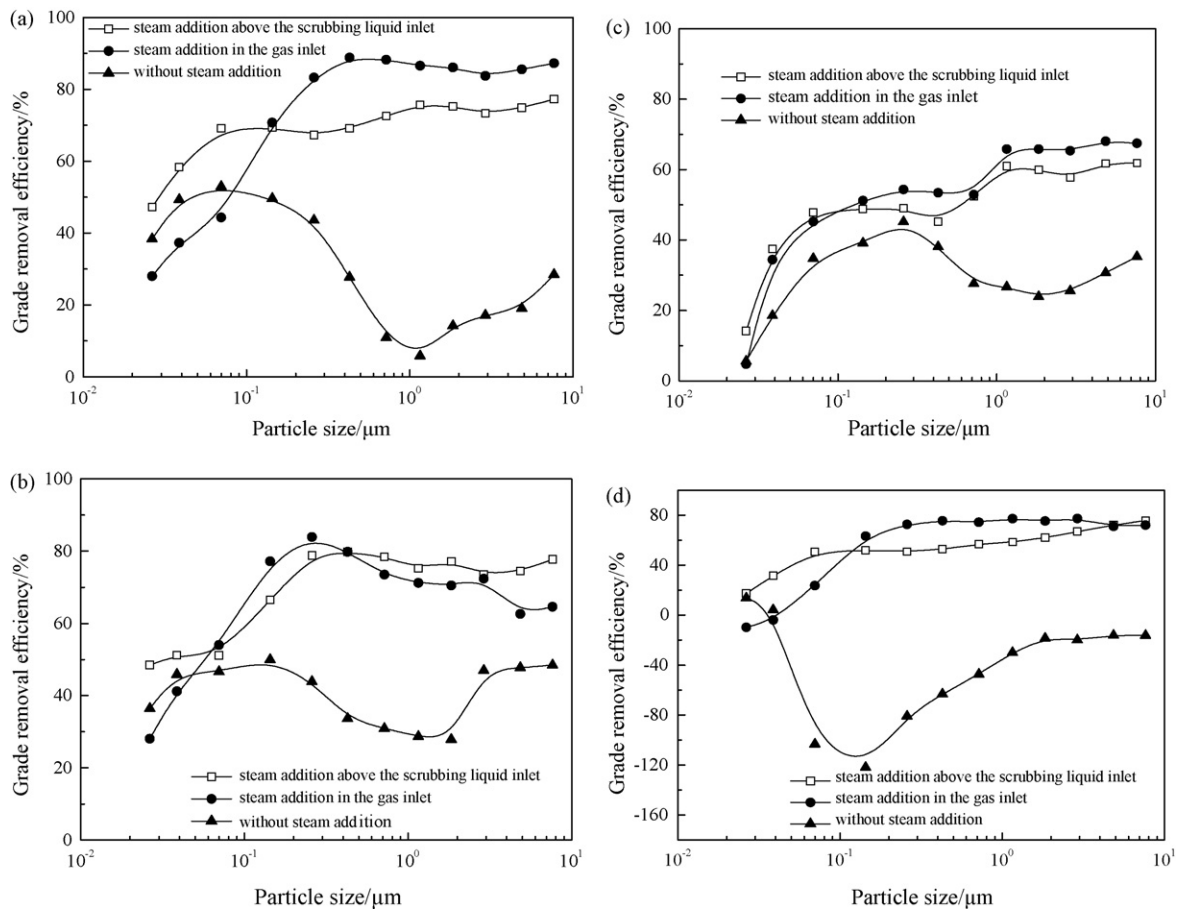

Fig. 6. Fine particle grade removal efficiency by WFGD system with different reagents at $L/G = 15 \text{ LN m}^{-3}$, $C_N \approx (2.0\text{--}3.0) \times 10^7 \text{ cm}^{-3}$, $m_s = 0.06 \text{ kg N m}^{-3}$. (a) Water scrubbing, (b) Na_2CO_3 solution scrubbing, (c) CaCO_3 slurry scrubbing and (d) $\text{NH}_3 \cdot \text{H}_2\text{O}$ solution scrubbing.

Moreover, it can be seen from Fig. 6 that smaller particles ($<0.1 \mu\text{m}$) have low removal efficiency, not only before steam addition also after steam addition. For the former case, it may be related to the size distribution characteristics of the particles employed, which is mostly in size below $0.1 \mu\text{m}$ with a maximum number concentration at $0.07 \mu\text{m}$, as shown in Fig. 2. On the one hand, the removal effect of scrubbing liquid and demister on small particle ($<0.1 \mu\text{m}$) increases with decreasing particle size due to the enhancement of diffusional forces. On the other hand, the particle number concentration can also be reduced by Brownian coagulation, which is most noticeable in the size range of $0.07\text{--}0.1 \mu\text{m}$ as a result of high number concentration. Wang et al. [2] also obtained similar results by investigating the removal effect of WFGD system on fine particles from a coal-fired power plant. Kim et al. [22] found that the particles smaller than $0.1 \mu\text{m}$ tend to collide and adhere into larger particles by mechanisms of diffusional deposition and Brownian coagulation. For the cases with steam addition, heterogeneous condensation of vapor causes the fine particles to grow into larger droplets, and the water vapor is more susceptible to condensate on the larger particle and hence the vapor amount condensated increases with the initial particle size. However, further studies will still be needed to confirm the results by investigating the influence of particle size distribution on grade removal efficiency using other particle source.

Fig. 6(a–d) also indicates that with steam addition the fine particle removal efficiency with Na_2CO_3 reagent is higher than those with CaCO_3 and $\text{NH}_3\cdot\text{H}_2\text{O}$ reagents, which is the same as that without steam addition (see Fig. 4). When using Na_2CO_3 to remove SO_2 from flue gas, nearly all of the sodium salt products, such as Na_2SO_4 and Na_2SO_3 , are dissolved due to their high water solubility, so that no aerosol particles are formed in the scrubber. However, when CaCO_3 is used as the reagent the product sulfates and sulfites tend to form fine crystals as a consequence of their slight solubility in water, and unreacted limestone particulates can also be present. The fine particles in flue gas are then a mixture of sulfates, sulfites, unreacted limestone and coal-fired fly ash. For $\text{NH}_3\cdot\text{H}_2\text{O}$ reagent, crystalline particles such as $(\text{NH}_4)_2\text{SO}_3$, NH_4HSO_3 and $(\text{NH}_4)_2\text{SO}_4$ may be formed mainly through gas phase reaction between SO_2 in the flue gas and gaseous ammonia volatilized from ammonia solution, and most particles formed can be ascribed to $\text{PM}_{2.5}$, as shown in Fig. 6(d). Consequently, the fine particle number concentration for CaCO_3 and $\text{NH}_3\cdot\text{H}_2\text{O}$ reagent is higher than that for Na_2CO_3 reagent. With an increase in the particle number, the amount of condensable water vapor is distributed among more particles and the droplets grow to a smaller size. Since the inertia of droplets decreases with decreasing size, the removal efficiency of the droplets by the scrubbing liquid and demister is lowered.

3.3.2. Influence of the amount of added steam

Fig. 7(a and b) shows the total number removal efficiency of fine particles by the WFGD system with steam addition in the gas inlet and above the scrubbing liquid inlet, respectively. The removal efficiency appears to increase slightly (except with $\text{NH}_3\cdot\text{H}_2\text{O}$ as reagent) when the amount of steam added is less than 0.02 kg m^{-3} , and then to increase rapidly. For example, when the amount of steam added in the gas inlet increases from 0.02 to 0.08 kg N m^{-3} , the removal efficiency increases from 50% and 40% , to 85% and 67% for Na_2CO_3 and CaCO_3 reagent, respectively. With increasing steam addition both the degree and the zone of supersaturation rise, leading to the amount of condensable water vapor increasing. Consequently, the more steam that is added, the larger the condensational droplets will be and the easier they can be removed by inertial forces. Moreover, due to the formation of aerosol particles in the limestone and ammonia-based processes, the removal efficiency is lower than those with Na_2CO_3 reagent and water scrubbing. Yan et al. [14] have shown that removal efficiencies

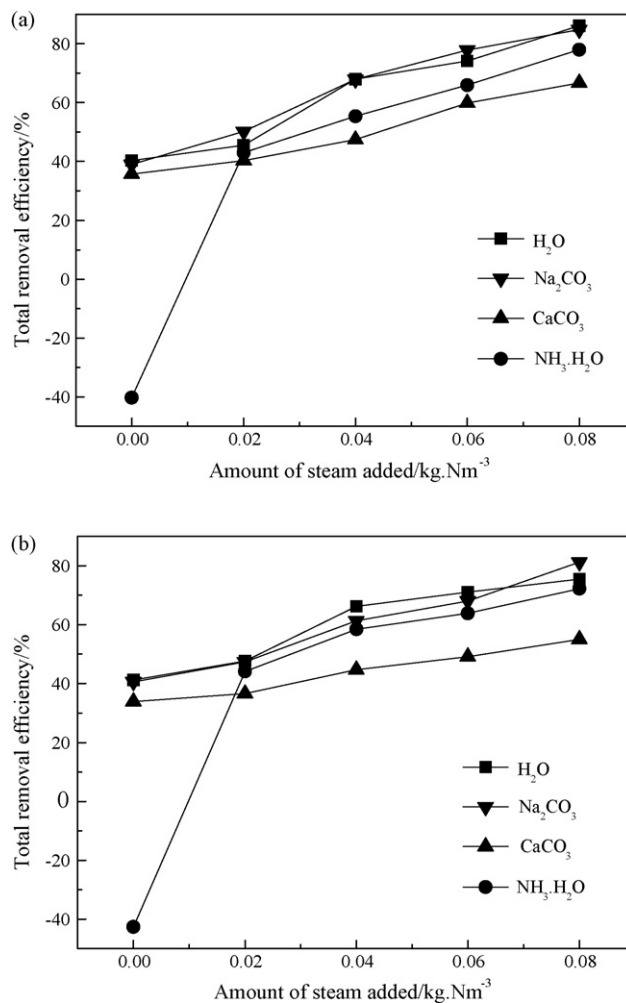

Fig. 7. Removal efficiency of fine particles as a function of the amount of steam added at $L/G = 15 \text{ L N m}^{-3}$, $C_N \approx (2.0\text{--}3.0) \times 10^7 \text{ cm}^{-3}$. (a) Steam addition in the gas inlet and (b) steam addition above the scrubbing liquid inlet.

higher than $50\text{--}60\%$ can be achieved for coal-fired fine particles with mean diameter $0.30 \mu\text{m}$ at 0.15 kg N m^{-3} steam addition. In their experiments, a heterogeneous condensational chamber was set upstream to the wet scrubber, and the fine particles were first enlarged by heterogeneous condensation of water vapor then removed by the wet scrubber. On the basis of the results obtained with the present novel process, it is clear that the amount of steam added can be significantly reduced. The main advantage of steam addition in the gas inlet of scrubber is that not only supersaturation and subsequently particle condensational growth can be realized, but also removal of the grown droplets takes place simultaneously. For the case of steam addition above the scrubbing liquid inlet, a high-efficiency demister is necessary.

Fig. 7(a and b) also indicates that when $\text{NH}_3\cdot\text{H}_2\text{O}$ is used as reagent, the removal efficiency of fine particles increased rapidly from about -40% to more than 40% with addition of 0.02 kg N m^{-3} steam. The reason is that a large quantity of soluble salts such as $(\text{NH}_4)_2\text{SO}_3$, NH_4HSO_3 and $(\text{NH}_4)_2\text{SO}_4$ can be formed during the ammonia-based FGD process, so the fine particles are actually a mixture of coal-fired fly ash and water-soluble ammonium salt particles. Due to the reduction of the vapor pressure caused by the solution effect, soluble particles can be activated at a much lower degree of supersaturation compared with insoluble particles. In a high humidity environment, soluble particles can deliquesce and gradually form solution droplets by absorbing moisture from the

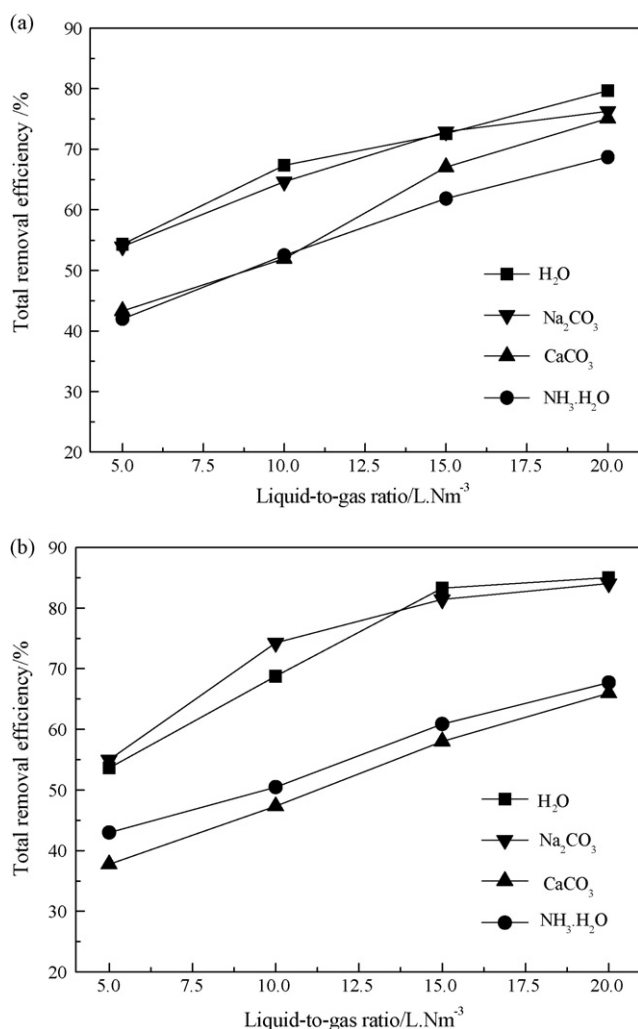

Fig. 8. Removal efficiency of fine particles as a function of liquid-to-gas ratio at $m_s = 0.06 \text{ kg N m}^{-3}$, $C_N \approx (2.0\text{--}3.0) \times 10^7 \text{ cm}^{-3}$. (a) Steam addition in the gas inlet and (b) steam addition above the scrubbing liquid inlet.

gas, so that condensational growth can occur under unsaturated conditions [23,24]. Fan et al. [25] found that higher mass content of the soluble salt favors the growth of the embryo droplet. For other reagents, however, the fine particles are all insoluble and a higher degree of supersaturation is required. In that case addition of 0.02 kg N m^{-3} of steam is insufficient to activate the insoluble particles.

3.3.3. Influence of liquid-to-gas ratio

In the WFGD process the liquid-to-gas ratio is an important operational parameter that can influence SO_2 removal and gas–liquid mass and energy transfer characteristics. The number removal efficiencies of fine particles for steam addition in the gas inlet and above the scrubbing liquid inlet are shown in Fig. 8(a and b) as a function of liquid-to-gas ratio. It is apparent that particle removal efficiency increased with increasing liquid-to-gas ratio for both cases of steam addition. For example, when using Na_2CO_3 as reagent, with an increase in liquid-to-gas ratio from 5.0 to 20 L N m^{-3} the removal efficiency increased from 54% to 76% and 84%, for steam addition in the gas inlet and above the scrubbing liquid inlet, respectively. In both cases, a supersaturated vapor phase can be achieved in the scrubber and the effectiveness of the WFGD system for removal of fine particles is improved by heterogeneous condensation of water vapor. For the former case,

higher liquid-to-gas ratio intensifies the energy and mass transfer between the scrubbing liquid and the gas stream, thus the degree of supersaturation of the vapor phase increases and particle enlargement by heterogeneous condensation is enhanced. Consequently, the removal of fine particles is improved. For the latter case, the temperature of the flue gas at the outlet of the SO_2 absorption zone decreases with increasing liquid-to-gas ratio. In the experiments, the gas temperature of condensational growth zone was in the range of $45\text{--}60^\circ\text{C}$, which accords with the flue gas temperature at the outlet of desulfurization towers in power plants. With the same moisture content of gas stream, the degree of supersaturation increases as the gas temperature decreases, more particles are activated, and the amount of condensable vapor for each particle increases. Thus the removal efficiency by inertial forces is improved.

By contrast, the fine particle removal performance is scarcely influenced by the liquid-to-gas ratio without steam addition, except for $\text{NH}_3\cdot\text{H}_2\text{O}$ as reagent (see Fig. 4). This can be attributed to the difference in the particle removal mechanism. Without steam addition, the fine particles with sizes mostly in the submicron range (see Fig. 2) are removed mainly by diffusional forces, and the effect of liquid-to-gas ratio is relatively unimportant. For $\text{NH}_3\cdot\text{H}_2\text{O}$ reagent, the increased removal efficiency with increase in the liquid-to-gas ratio is due to the decreased formation of aerosols in the SO_2 absorption process, as discussed in Section 3.2. The influence of the liquid-to-gas ratio is thus related to occurrence of heterogeneous condensation in the scrubber. When the flue gas achieves supersaturation and fine particles can be enlarged by heterogeneous condensation, a high liquid-to-gas ratio is beneficial to the removal of fine particles.

Additionally, it is also necessary to investigate the influence of the temperature of condensation growth zone on the removal efficiency. On the one hand, S_{cr} necessary for heterogeneous condensation of water vapor on particle surface would decrease with the increase in temperature. On the other hand, the supersaturation degree decreases with increasing temperature when the addition amount of water vapor keeps constant. However, it was impossible to perform such research based on the experimental system shown in Fig. 1.

4. Conclusions

A novel process to improve the effectiveness of the WFGD system for removal of fine particles is presented, based on enlargement of fine particles by heterogeneous condensation of water vapor. To achieve a supersaturated vapor phase in the SO_2 absorption zone and at the top of the wet FGD scrubber, steam was injected into the gas inlet and above the scrubbing liquid inlet of the scrubber. Experimental results indicate that the SO_2 absorbents used have an important influence on the effectiveness of the WFGD system for removal of fine particles. Use of CaCO_3 and $\text{NH}_3\cdot\text{H}_2\text{O}$ to remove SO_2 from flue gas gives fine particle removal efficiencies lower than is attained by use of Na_2CO_3 and water scrubbing. The lower fine particle removal efficiencies are a consequence of the formation of aerosols in SO_2 absorption process. Moreover, the morphology and elemental composition of the particles are changed. A supersaturated vapor phase, necessary for the condensational growth of fine particles, can be achieved by means of steam addition in the gas inlet or above the scrubbing liquid inlet of the scrubber, and both coal-fired fly ash and aerosol particles formed in the SO_2 absorption process can be efficiently removed. The removal efficiency rises with increasing amount of added steam. Number concentration removal efficiencies of at least 60–70% can be attained by adding $0.06 \text{ kg steam per N m}^3$ flue gas. The influence of liquid-to-gas ratio is related to occurrence of heterogeneous condensation in the scrubber. When the flue gas becomes supersaturated and

fine particles can be enlarged by heterogeneous condensation, a high liquid-to-gas ratio is beneficial to the removal of fine particles. The novel process offers the fundamentals of simultaneous, efficient removal of coal-fired fly ash and aerosol particles formed in SO₂ absorption. It has a high potential for industrial application by incorporation in the WFGD process, and exhaust steam and secondary steam from power plants can be used as vapor source when the technique is used in a real coal-fired power plant. To develop the novel technology, the experiments were also carried out using a rotating-stream-tray scrubber, and the results indicate that the removal performance of WFGD system on fine particles can also be improved by heterogeneous condensation. Additionally, further studies are planned to investigate the influence of particle size distribution and the temperature of condensation growth zone on removal efficiency.

Acknowledgements

The authors thank the National Natural Science Foundation of China (20576020), the Special Funds for Major State Basic Research Projects of China (2002CB211604), and the National High Technology Research and Development of China 863 Program (2008AA05Z306) for their financial support.

References

- [1] L.L. Sloss, I.M. Smith, PM₁₀ and PM_{2.5}: an international perspective, *Fuel Process. Technol.* 65–66 (2000) 127–141.
- [2] H. Wang, Q. Song, Q. Yao, Experimental study on removal effect of wet flue gas desulfurization system on fine particles from a coal-fired power plant, *Proc. CSEE* 28 (2008) 1–7.
- [3] R. Meij, Trace element behavior in coal-fired power plants, *Fuel Process. Technol.* 39 (1994) 199–217.
- [4] R. Meij, H. Winkel, The emissions and environmental impact of PM₁₀ and trace elements from a modern coal-fired power plant equipped with ESP and wet FGD, *Fuel Process. Technol.* 85 (2004) 641–656.
- [5] J. Yan, L. Yang, J. Bao, et al., Impact property on fine particles from coal combustion in ammonia flue gas desulfurization process, *Proc. CSEE* 29 (2009) 21–26.
- [6] S. Heidenreich, F. Ebert, Condensational droplet growth as a preconditioning technique for the separation of submicron particles from gases, *Chem. Eng. Process.* 34 (1995) 235–244.
- [7] S. Calvert, J. Goldschmid, D. Leith, Feasibility of flux force/condensation scrubbing for fine particulate collection, Report No. EPA 650/2-73-036. NTIS No. PB 227-307, A.P.T., Inc., October 1973.
- [8] P. Schauer, Removal of submicron particles from a moving gas stream, *Ind. Eng. Chem.* 43 (1951) 1532–1538.
- [9] B.W. Lancaster, W. Strauss, A study of steam injection into wet scrubbers, *Ind. Eng. Chem. Fundam.* 10 (1971) 362–368.
- [10] S. Calvert, N.C. Jhaveri, Flux force/condensation scrubbing, *J. Air Pollut. Control Assoc.* 24 (1974) 946–951.
- [11] T. Johannessen, J.A. Christensen, O. Simonsen, H. Livbjerg, The dynamics of aerosols in condensational scrubbers, *Chem. Eng. Sci.* 52 (1997) 2541–2556.
- [12] S. Heidenreich, U. Vogt, H. Büttner, F. Ebert, A novel process to separate submicron particles from gases—a cascade of packed columns, *Chem. Eng. Sci.* 55 (2000) 2895–2905.
- [13] U. Vogt, S. Heidenreich, Separation of submicron particles in packed columns—optimization and scale-up of the process, *Chem. Eng. Technol.* 22 (1999) 935–942.
- [14] J. Yan, L. Yang, X. Zhang, et al., Experimental study on separation of inhalable particles from coal combustion by heterogeneous condensation enlargement, *Proc. CSEE* 27 (2007) 12–16.
- [15] F. Fan, Study on growth mechanisms of inhalable particles in acoustic field and in supersaturated vapor environment, Ph.D. Dissertation, Southeast University, 2008.
- [16] L. Yang, X. Zhang, L. Sun, Analysis of cooperative removal of PM_{2.5} by heterogeneous condensation in wet flue gas desulfurization, *Modern Chem. Ind.* 27 (2007) 23–26, 28.
- [17] H. Yi, J. Hao, L. Duan, Characteristics of inhalable particulate matter concentration and size distribution from power plants in China, *J. Air Waste Manage. Assoc.* 56 (2006) 1–9.
- [18] J. Yan, L. Yang, X. Shen, Wettability of PM_{2.5} from combustion, *J. Southeast Univ.* 36 (2006) 760–764.
- [19] J.J. Helble, Mechanisms of ash formation and growth during pulverized coal combustion, Ph.D. Thesis, MIT: Department of Chemical Engineering, 1987.
- [20] M. Chen, B. He, G. Chen, et al., Chemical kinetics based analyses on SO₂ removal reactions by ammonia scrubbing, *Acta Sci. Circum.* 25 (2005) 886–890.
- [21] S. Sinanis, A. Wix, L. Ana, K. Schaber, Characterization of sulphuric acid and ammonium sulphate aerosols in wet flue gas cleaning processes, *Chem. Eng. Process.* 47 (2008) 22–30.
- [22] D.S. Kim, S.H. Park, Y.M. Song, D.H. Kim, K.W. Lee, Brownian coagulation of polydisperse aerosols in the transition regime, *J. Aerosol Sci.* 34 (2003) 859–868.
- [23] H.E. Gerber, W.A. Hoppel, T.A. Wojciechowski, Experimental verification of the theoretical relationship between size and critical supersaturation of salt nuclei, *J. Atmos. Sci.* 34 (1977) 1836–1841.
- [24] I.N. Tang, Phase transformation and growth of aerosol particles composed of mixed salts, *J. Aerosol Sci.* 7 (1976) 361–371.
- [25] F. Fan, L. Yang, Z. Yuan, J. Yan, Numerical analysis of water vapor nucleation on PM_{2.5} from municipal solid waste incineration, *Chem. Eng. J.* 146 (2009) 259–265.